

# MADI

ARCHITECTS + PLANNERS

## Measure A

### Soquel High School Campus Update



DECEMBER 17, 2019

# AGENDA

- △ BUDGET OVERVIEW
- △ COMPLETE PROJECTS
- △ ONGOING PROJECTS
- △ CLASSROOM MODERNIZATION
- △ WHAT'S NEXT

# SOQUEL HIGH SCHOOL

## Soquel High School – Measure A

PROJECT	START	COMPLETE	PROJECT BUDGETS
Multi-Project Overhead	ONGOING	ONGOING	\$1,703,567
Pool <i>(by Belli)</i>	COMPLETE	COMPLETE	\$7,514,060
Site Infrastructure	COMPLETE	COMPLETE	\$3,235,000
New Concessions Building & Ramp	COMPLETE	COMPLETE	\$1,842,438
Tennis Courts	COMPLETE	COMPLETE	\$221,361
Modernization Phase 1: Reverse TI	COMPLETE	COMPLETE	\$800,000
Modernization Phase 2: Wing 100	08/16/2019	12/31/2019	\$6,097,270
Modernization Phase 3: Wing 200	01/01/2020	08/23/2020	\$5,878,870
Modernization Phase 4: Wing 300	-	-	\$3,000,000
Site Work	06/08/2020	08/23/2020	\$610,000
Card Access Security System	06/10/2019	08/21/2020	\$310,000
Data Infrastructure Improvements	06/10/2019	08/21/2020	\$700,000
Fields <i>(Sunk Cost)</i>	-	-	\$1,527,272



### ORIGINAL PROJECT BUDGETS

*Soquel High School Bond Projects*



# Soquel High School – Measure A

PROJECT	PROJECT BUDGETS
Multi-Project Overhead	\$1,703,567
Pool <i>(by Belli)</i>	\$7,514,060
Site Infrastructure	\$3,235,000
New Concessions Building & Ramp	\$1,842,438
Tennis Courts	\$221,361
Modernization Phase 1: Reverse TI	\$800,000
Modernization Phase 2: Wing 100 & 200	\$9,908,388
Site Work	\$610,000
Card Access Security System	\$310,000
Data Infrastructure Improvements	\$700,000
Fields <i>(Sunk Cost)</i>	\$1,527,272
<i>PROJECT CONSTRUCTION COSTS TO DATE:</i>	\$28,375,086
<i>EST. REMAINING CONSTRUCTION BUDGET:</i>	\$2,276,160



## UPDATED PROJECT BUDGETS

*Soquel High School Bond Projects*



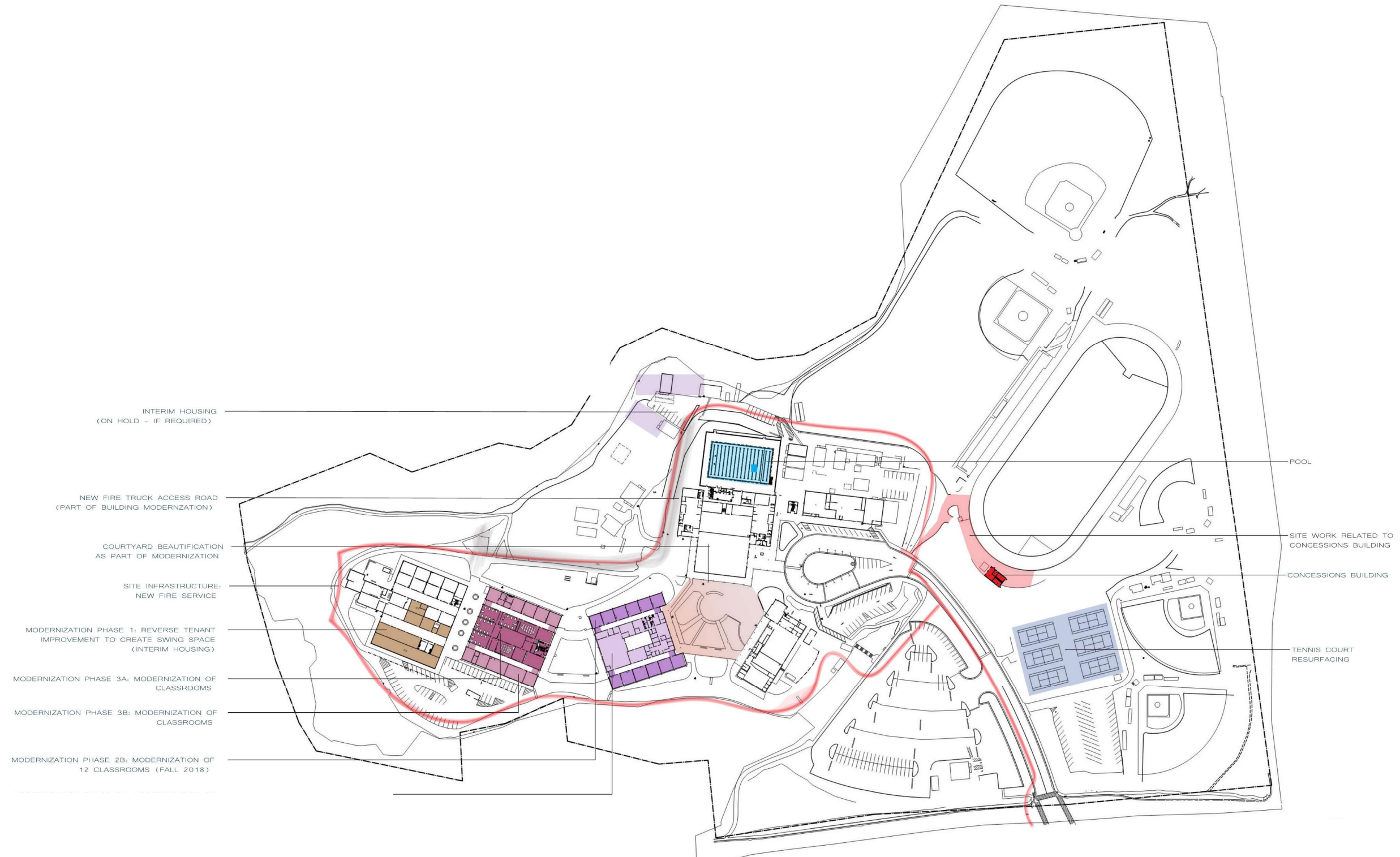

## SITE MASTERPLAN

*Soquel High School Bond Projects*





**PREVIOUSLY COMPLETED – POOL** *(by Belli Architects)*

*Soquel High School Bond Projects*





## **PREVIOUSLY COMPLETED – TENNIS COURT RESURFACING**

*Soquel High School Bond Projects*



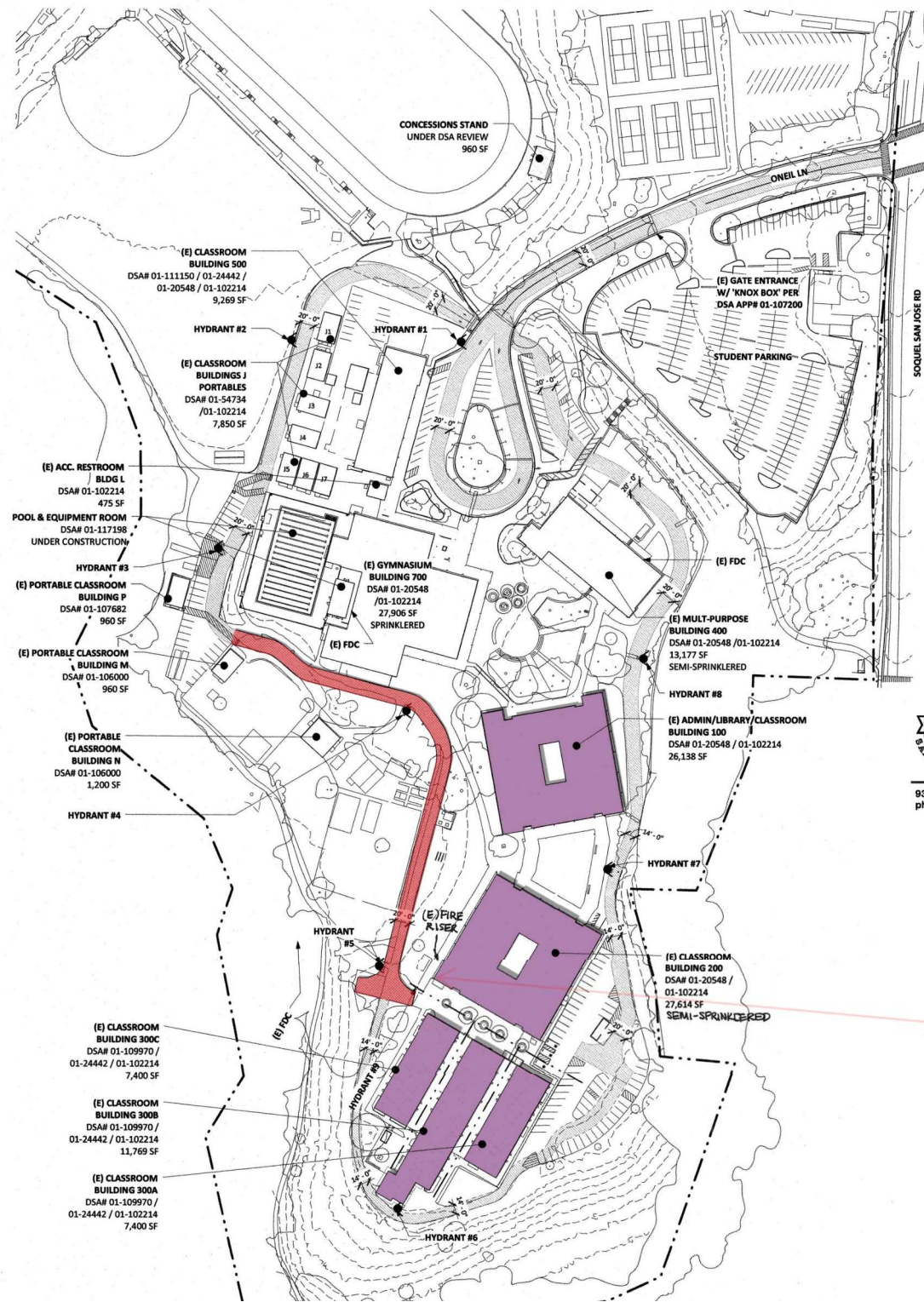

**SCOPE:**

REPLACEMENT OF EXISTING  
FIRE LANE WITH NEW WIDER  
FIRE LANE

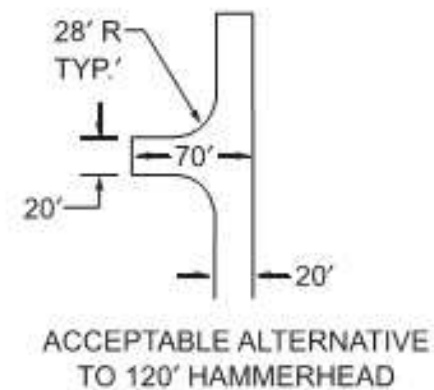
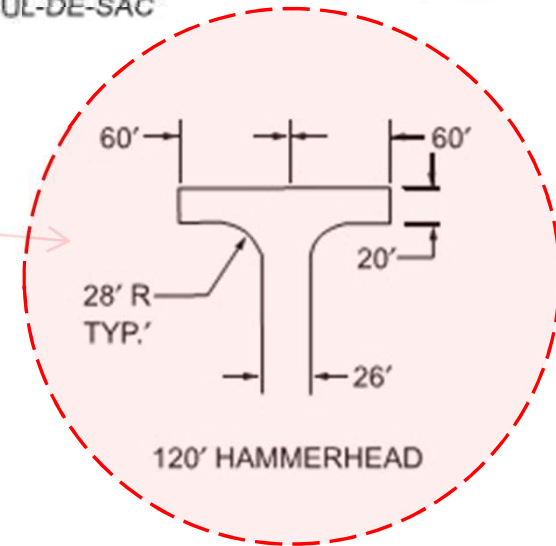
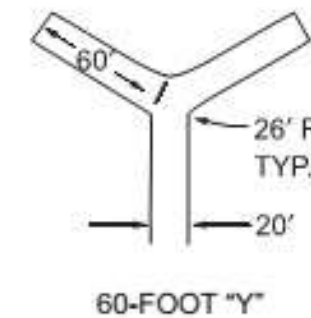
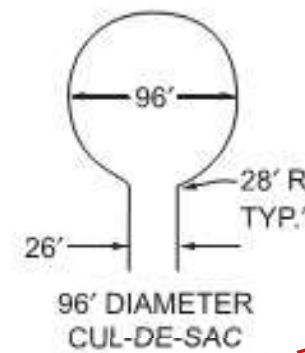

**RECENTLY COMPLETED – FIRE ROAD**

*Soquel High School Bond Projects*







## **RECENTLY COMPLETED— SITE INFRASTRUCTURE & FIRE ROAD**

*Soquel High School Bond Projects*





## **RECENTLY COMPLETED – WING 300 MODERNIZATION (REVERSE T&I)**

*Soquel High School Bond Projects*





**ONGOING ITEMS:**

- EXTERIOR PARTITIONS
- ONGOING COUNTY HEALTH DEPT. REVIEW

**CONSTRUCTION 95% COMPLETE**



**ONGOING CONSTRUCTION— CONCESSIONS BUILDING & ADA RAMP**

*Soquel High School Bond Projects*





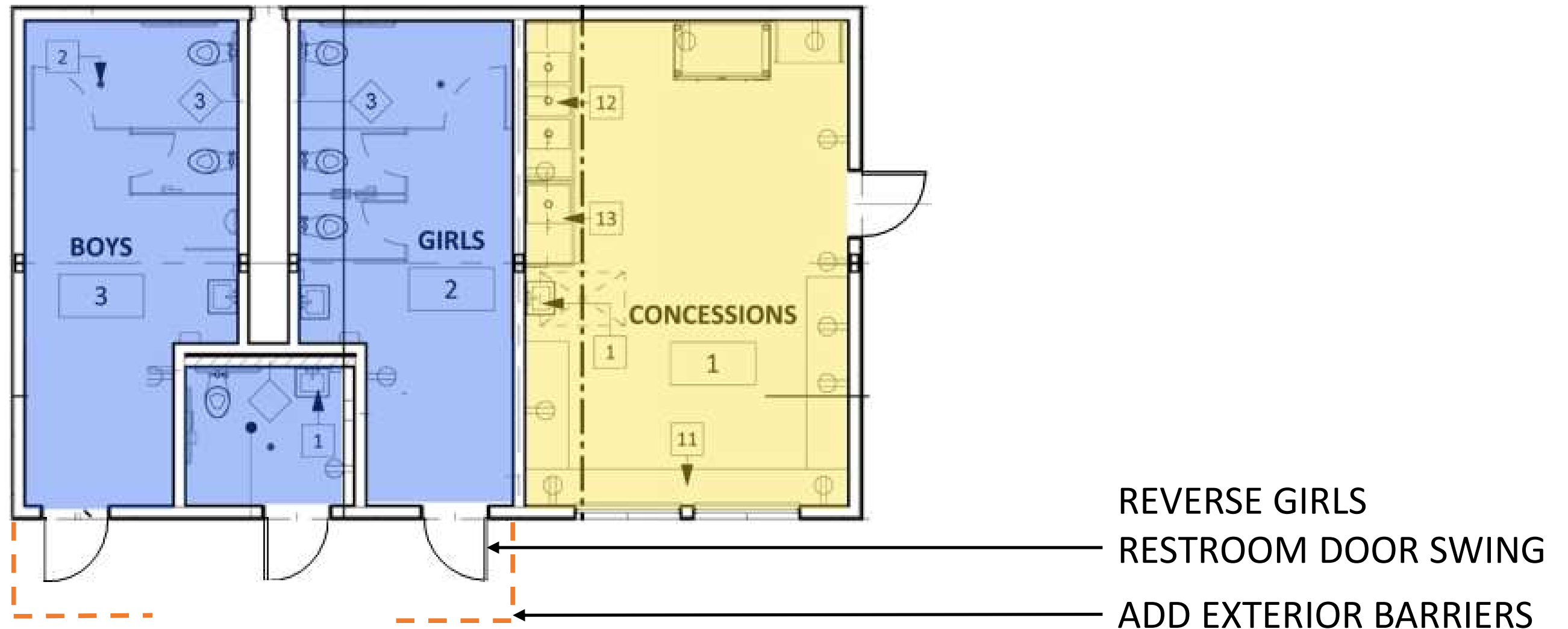

**CONSTRUCTION 95% COMPLETE**

**\*Ongoing work proceeding with site contractor and SCCS District Staff**



## **ONGOING CONSTRUCTION— CONCESSIONS BUILDING & ADA RAMP**

*Soquel High School Bond Projects*







**ADMINISTRATION CONSTRUCTION**

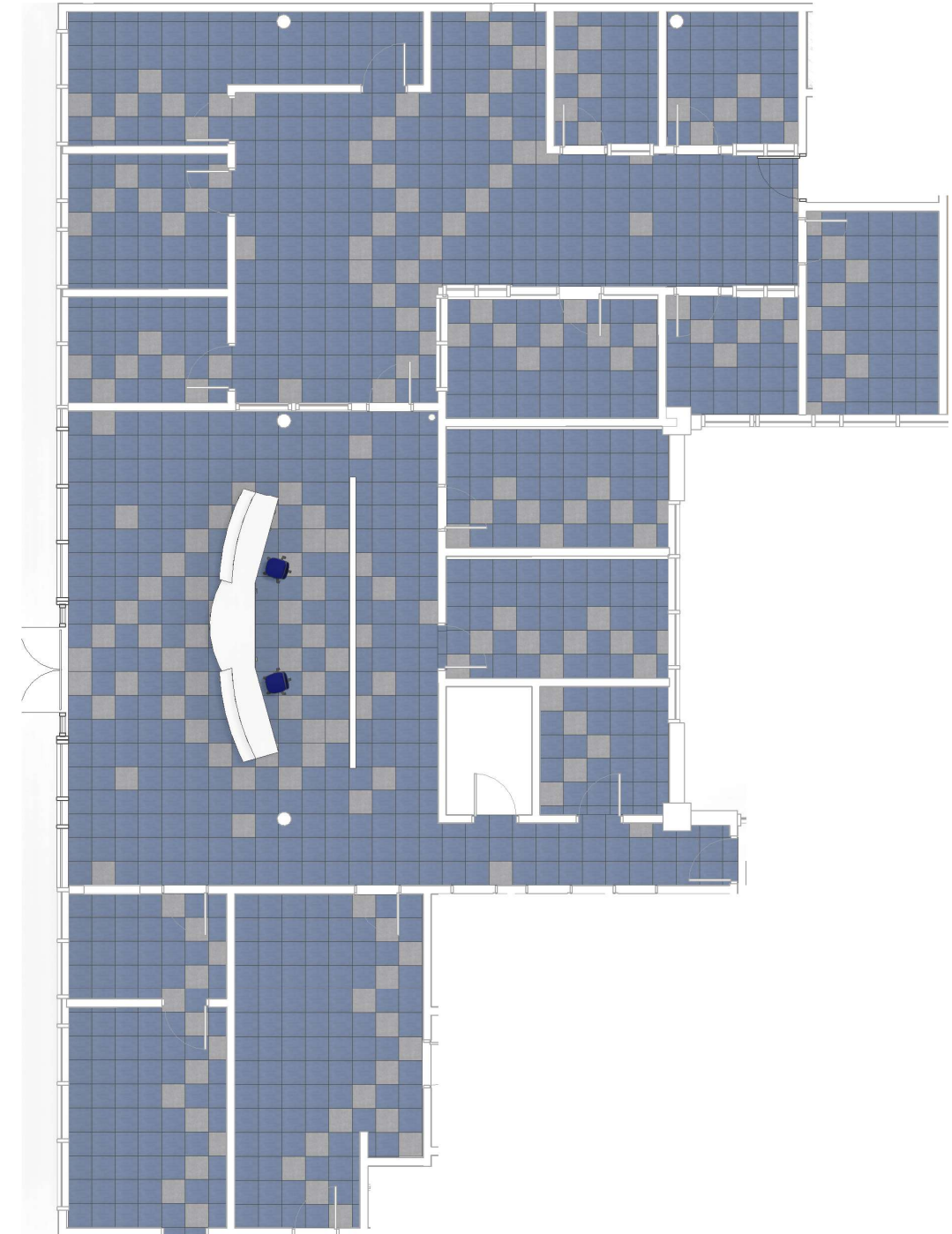
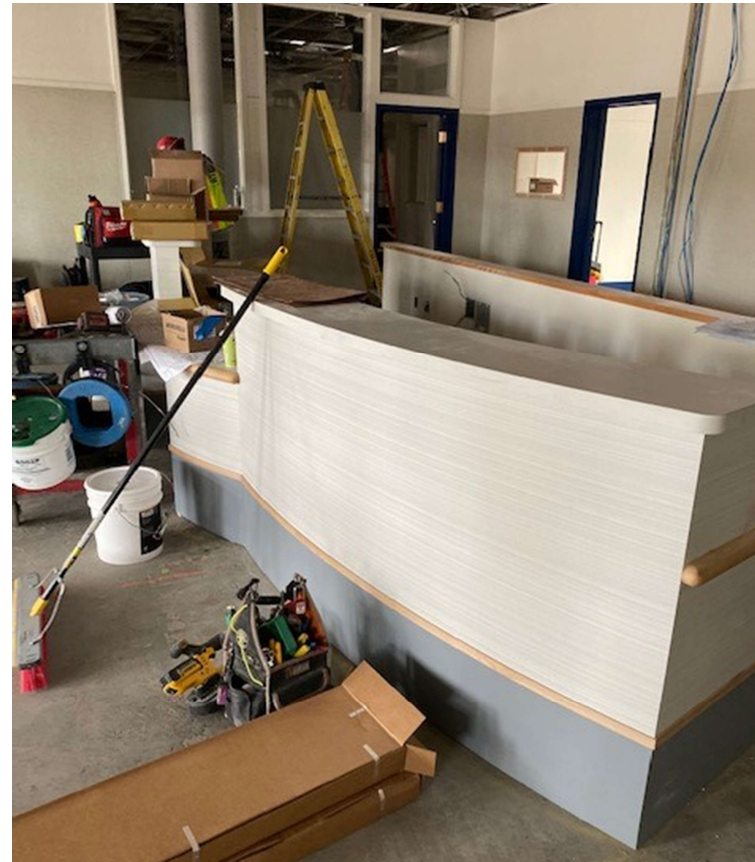

**ADMINISTRATION CARPET LAYOUT**



**NEW ADMINISTRATION STOREFRONT**

**ONGOING CONSTRUCTION – WING 100 MODERNIZATION (ADMINISTRATION)**

*Soquel High School Bond Projects*







**LIBRARY MODERNIZATION RENDER**



**LIBRARY MODERNIZATION**



**ONGOING CONSTRUCTION – WING 100 MODERNIZATION (LIBRARY)**

*Soquel High School Bond Projects*







**LIBRARY MODERNIZATION RENDER**

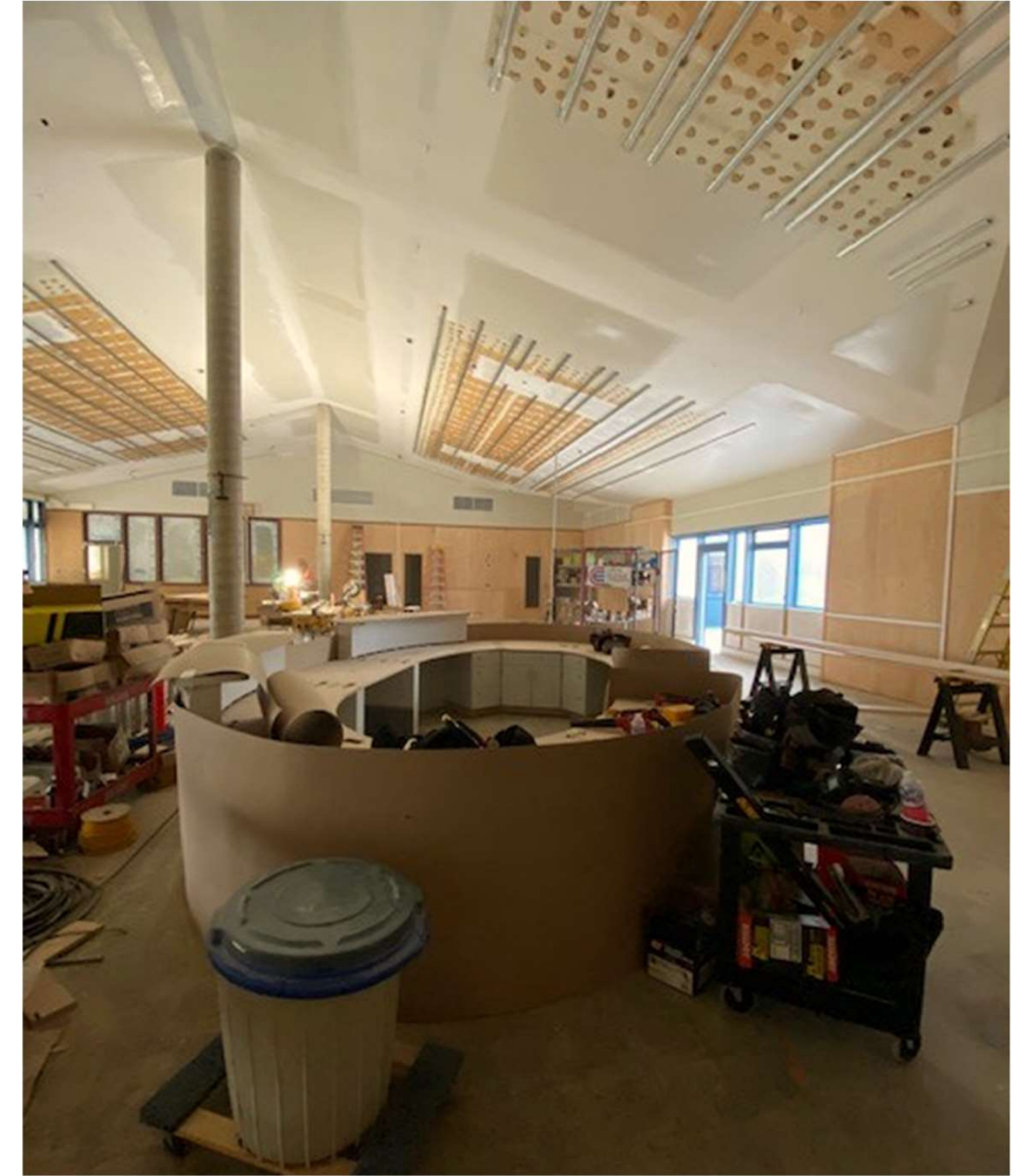

**LIBRARY CONSTRUCTION**



## **ONGOING CONSTRUCTION - LIBRARY**

*Soquel High School Bond Projects*





## ONGOING CONSTRUCTION – WING 100 MODERNIZATION

*Soquel High School Bond Projects*







## ONGOING CONSTRUCTION – WING 100 MODERNIZATION

*Soquel High School Bond Projects*



**PHASE 1**



**PHASE 2**

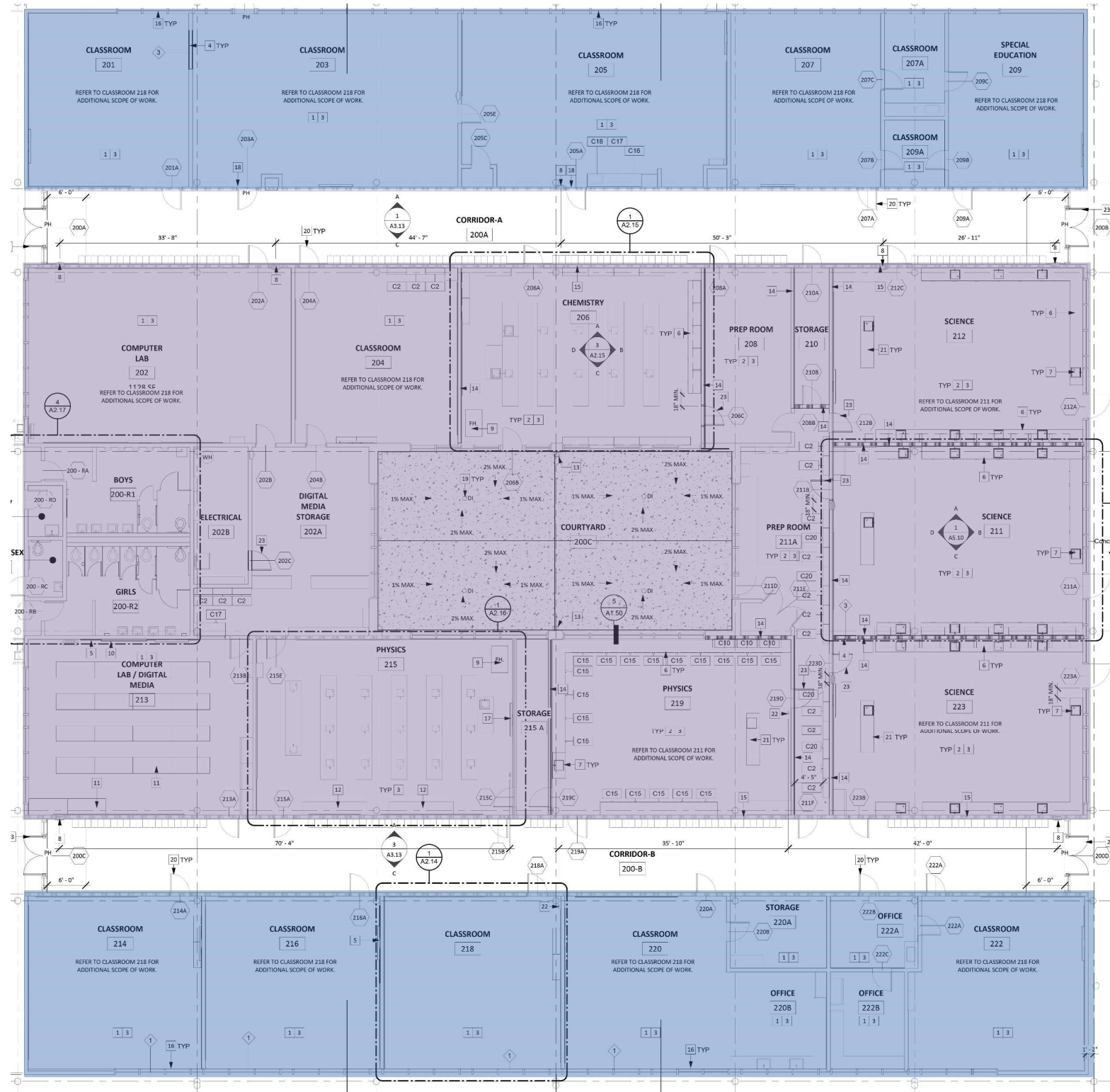

**SCOPE:**

- CLASSROOM MODERNIZATION
  - SCIENCE
  - COMPUTER LABS
  - SPECIAL EDUCATION
  - WORLD LANGUAGE
  - ENGLISH

**KEY DATES:**

- FEBRUARY 2020 START
- AUGUST 2020 COMPLETION



# UPCOMING CONSTRUCTION – WING 200 MODERNIZATION

*Soquel High School Bond Projects*







PENDANT LIGHTING



ROLLER SHADES



ELECTRONIC LOCKS



CEILING FANS



CLASSROOM FINISHES



ACOUSTICAL PANELS

### CLASSROOM MODERNIZATION:

- NEW DUAL ROLLER SHADES
- NEW LIGHTING
- NEW CEILING FANS
- NEW INTERIOR & EXTERIOR PAINT
- NEW TELEVISIONS
- NEW CLASSROOM FURNITURE
- NEW WINDOW FILMS
  - ENERGY EFFICIENCY COATING
  - SECURITY FILM
- NEW CEILING ACOUSTICAL PANELS
- NEW ELECTRONIC LOCKS
- HVAC UPGRADES
- ELECTRICAL UPGRADES
- FIRE SPRINKLER REPAIRS
- COURTYARD REPAIRS



## ONGOING PROJECTS – CLASSROOM MODERNIZATION

*Soquel High School Bond Projects*



## WHAT'S NEXT

### MODERNIZATION

- MOD. WING 100 COMPLETION BY FEBRUARY 2020
- START MOD. WING 200 ON FEBRUARY 2020

### SITE BOND COMMITTEE MEETING

- DISCUSS NEW CAMPUS PRIORITIES
  - STUDENT SOFT SCAPE AREAS
  - EXTERIOR BEAUTIFICATION (HIDE EXPOSED UTILITIES)
  - NEW FLOORING IN CLASSROOMS & CORRIDORS



## WHAT'S NEXT– UPCOMING MEETINGS & PROJECTS

---

*Soquel High School Bond Projects*

**THANK YOU!**

**MADI**  
ARCHITECTS + PLANNERS